



CustomControlSensors

Non-Hazardous Areas Adjustable Pressure Switch

604G* - Diaphragm Sensor



DESCRIPTION

- Highly reliable devices utilizing the CCS Dual-Snap® Belleville disc spring principle pioneered by CCS' engineers.
 - Engineering based on aerospace technology.
 - Rigid, midsize and internally adjustable for convenient field set point adjustment.
 - Repeatable and stable set points.
 - Vibration and shock resistant.
 - High cycle life.
 - High over-pressure capability. (System and Proof)
- Various options for wetted materials and electrical ratings to meet a wide range of application requirements and media compatibility.

SHIPPING WEIGHT: APPROXIMATELY 39 OUNCES (1092 GRAMS)

SERIES:

604G*

ADJUSTABLE SET POINT RANGE:

0.3 to 5000 PSIG
0.02 to 345 bar
2.07 to 34474 kPa

OPERATING TEMPERATURE:

Temperature limits change with O-ring selection.

-40° to 186°F
-40° to 86°C

STANDARD FEATURES:

- CE Mark
- CRN
- CCC
- NACE MR0175 / ISO 15156
- NEMA: 4,13 / IP65
- Weatherproof
- Internal Case Ground
- U.L. Listed (File No. E72038)

INSTALLATION DRAWING

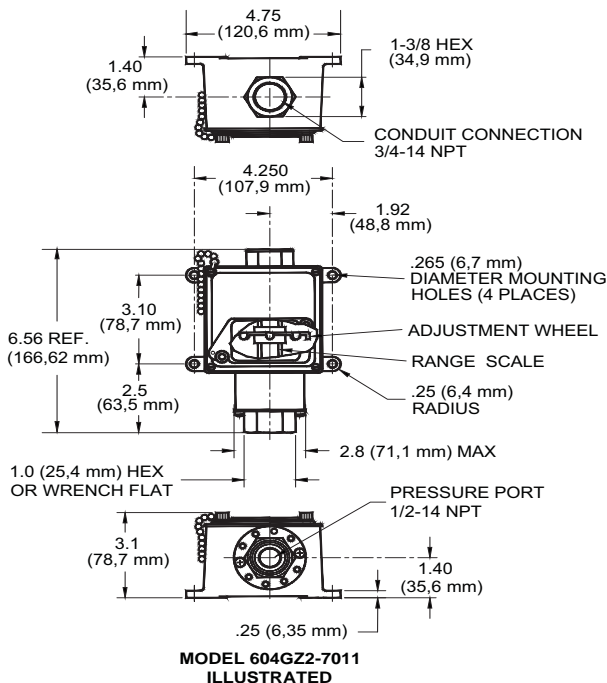

DESIGN PRINCIPLES

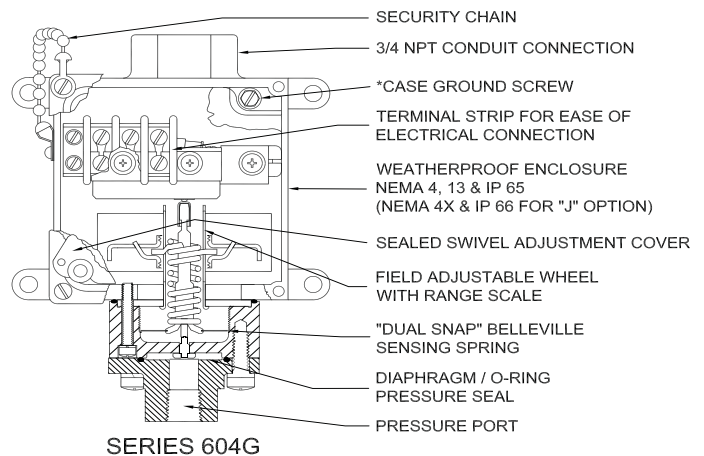

SCHEMATIC AND WIRING CODE

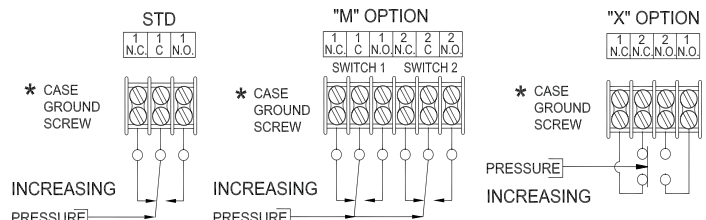

FIELD SETTING: Open access cover. Adjust wheel as illustrated. Clockwise to increase settings. Counterclockwise to decrease settings.

NOTE: DO NOT USE ELECTRICAL HEX FOR TORQUING.

DUAL-SNAP®

ccsdualsnap.com



Models: 604G*, Page 1 of 2
Form 830G, 7.12.13



CustomControlSensors

Non-Hazardous Areas Adjustable Pressure Switch

604G* - Diaphragm Sensor

OPERATING AND ORDERING DATA

SERIES 604G*	WETTED PARTS: 1/4"-18 NPT ALUMINUM PRESSURE PORT, POLYIMIDE DIAPHRAGM, BUNA N O-RING				
	ADJUSTABLE SET POINT RANGE		APPROX. DEAD BAND PSI (BAR)	SYSTEM PRESSURE PSIG (BAR)	PROOF PRESSURE PSIG (BAR)
	INCREASING PRESSURE PSIG (BAR)	DECREASING PRESSURE PSIG (BAR)			
604G*1	1-16 (0.07-1.1)	.3-15.3 (0.02-1.05)	.7 (0.05)	500 (34.5)	750 (51.7)
604G*M*1	1.2-18 (0.08-1.2)	.4-17.2 (0.03-1.18)	.8 (0.05)		
604G*2	8-75 (0.6-5.2)	3-70 (0.2-4.8)	5 (0.34)	3000 (207)	5000 (345)
604G*11	20-150 (1.4-10.3)	8-138 (0.6-9.5)	12 (0.8)		
604G*3	50-375 (3.5-25.9)	22-347 (1.5-23.9)	28 (1.9)		
604G*5	330-1000 (22.8-68.9)	265-935 (18.3-64.5)	65 (4.5)		
SERIES 604GZ*	WETTED PARTS: 1/2"-14 NPT 316 STAINLESS STEEL PRESSURE PORT, POLYIMIDE DIAPHRAGM, VITON O-RING				
	ADJUSTABLE SET POINT RANGE		APPROX. DEAD BAND PSI (BAR)	SYSTEM PRESSURE PSIG (BAR)	PROOF PRESSURE PSIG (BAR)
	INCREASING PRESSURE PSIG (BAR)	DECREASING PRESSURE PSIG (BAR)			
604GZ*1	1.2-16 (.08-1.1)	.4-15.2 (0.03-1.04)	.8 (0.05)	500 (34.5)	750 (51.7)
604GZ*M*1	1.2-16 (0.08-1.1)	.4-15.2 (0.03-1.04)	.8 (0.05)		
604GZ*2	8-75 (0.6-5.2)	3-70 (0.2-4.8)	5 (0.34)	3000 (207)	5000 (345)
604GZ*11	20-150 (1.4-10.3)	8-138 (0.6-9.5)	12 (0.8)		
604GZ*3	50-375 (3.5-25.9)	22-347 (1.5-23.9)	28 (1.9)		
604GZ*5	330-1000 (22.8-68.9)	265-935 (18.3-64.5)	65 (4.5)		
604GZ*7	950-2300 (65.5-159)	775-2125 (53.4-147)	175 (12.1)		
SERIES 604GZ*-7011	WETTED PARTS: 1/2"-14 NPT 316 STAINLESS STEEL PRESSURE PORT & DIAPHRAGM, VITON O-RING				
	ADJUSTABLE SET POINT RANGE		APPROX. DEAD BAND PSI (BAR)	SYSTEM PRESSURE PSIG (BAR)	PROOF PRESSURE PSIG (BAR)
	INCREASING PRESSURE PSIG (BAR)	DECREASING PRESSURE PSIG (BAR)			
604GZ*1-7011	1.4-16 (.09-1.1)	.4-15 (0.03-1.03)	1 (0.07)	500 (34.5)	750 (51.7)
604GZ*2-7011	10-75 (.7-5.2)	3-68 (0.2-4.7)	7 (0.5)		
604GZ*11-7011	20-150 (1.4-10.3)	6-136 (0.4-9.4)	14 (0.97)	3000 (207)	5000 (345)
604GZ*3-7011	50-375 (3.5-25.9)	16-341 (1.1-23.5)	34 (2.3)		
604GZ*5-7011	330-1000 (22.8-68.9)	250-920 (17.2-63.4)	80 (5.5)		
604GZ*7-7011	950-2300 (65.5-159)	750-2100 (51.7-145)	200 (13.8)		
604GZ*9-7011	2100-3400 (145-234)	1820-3120 (126-215)	280 (19.3)	5000 (345)	7500 (517)
604GZ*10-7011	3200-5000 (221-345)	2720-4520 (187.5-312)	480 (33.1)		

HOW TO ORDER

Follow these steps to build your part number:

1. Specify the series based on your required set point, range, dead band, system pressure and proof pressure.
2. Add desired options model code letter.
3. Add the applicable standard suffix number.

(Ex: 604GM1-7008)

PRESSURE CONVERSION

1 BAR = 14.5 PSI
1 kPa = 0.145 PSI

OPTIONS MODEL CODES

- A:** Viton® O-Ring (STD on GZ models)
- C:** 316 Stainless Steel Welded Capsule (Ranges 9 and 10 not available)
- F:** Ethylene Propylene O-Ring
- J:** CSA Approved (File No. LR22665) (SPDT ONLY)
- M:** DPDT Electrical
- X:** Double Break Switching Element

OPTIONAL STANDARD MODIFIED SUFFIXES

- 7008:** Gold Contacts
- 7023:** Manual Reset after Increasing
- 7032:** Viton Dacron Diaphragm and Viton® O-Ring (GZ models only)
- 7044:** Monel Port and Diaphragm (GC models only)
- 7045:** Hastelloy C-276 Port and Diaphragm (GC models only)
- 7044/7045:** Ranges 1, 9 and 10 not available

7063: 1/4 inch BSP and M20 Electrical Connection

Note: Additional modified standard suffixes are available, consult CCS sales department or CCS Representative.

CERTIFICATIONS

Consult CCS website for complete certification and approval listing.

ELECTRICAL CHARACTERISTICS

RATING OF SWITCH ELEMENT

VOLTS	AMPERES		
	SPDT Res.	DPDT "M" Res.	Dbl Brk "X" Res.
125 AC - 50/60 Hz	15	5	15
250 AC - 50/60 Hz	15	5	15
480 AC - 50/60 Hz	15	-	15
28 DC	6	5	-
125 DC	.5	.5	1
250 DC	.2	-	.5
*125 AC - 50/60 Hz	1 max	1 max	-
*30 DC	1 max	1 max	-

*Gold Contacts -7008 Suffix